

Ldrive 36W

Dual-channel constant current LED driver



INSTALLATION AND QUICK START SHEET

⚠ WARNING AND GUIDELINES!!!

Read and follow all safety instructions!!

DO NOT INSTALL DAMAGED PRODUCT! This product has been properly packed so that no parts should have been damaged during transit. Inspect to confirm. Any part damaged or broken during or after assembly should be replaced.

WARNING : TURN THE POWER OFF AT THE CIRCUIT BREAKER BEFORE WIRING

WARNING: Risk of Product Damage

- Electrostatic Discharge (ESD): ESD can damage product(s). Personal grounding equipment should be worn during all installation or servicing of the unit
- Do not stretch or use cable sets that are too short or are of insufficient length
- Do not modify the product
- Do not mount near gas or electric heater
- Do not change or alter internal wiring or installation circuitry
- Do not use product for anything other than its intended use

WARNING - Risk of Electric Shock

- Verify that supply voltage is correct by comparing it with the product information
- Make all electrical and grounded connections in accordance with the National Electrical Code (NEC) and any applicable local code requirements
- All wiring connections should be capped with UL approved recognized wire connectors

PRODUCT OVERVIEW

Ldrive 36W is a dual-channel constant current LED driver with programmable output current. It is a part of Lumos Controls ecosystem which includes controllers, sensors, switches, modules, drivers, gateways, and analytical dashboards.



REQUIRED TOOLS & SUPPLIES



Screwdriver



Screws

Prior to mounting, turn on power and test connection to ensure system is operating properly. Turn off power again before mounting.

INSTALLATION INSTRUCTIONS

Wiring instructions

- Check the polarity of the output terminals
- The LED wiring should be kept as short as possible to ensure good EMI behavior
- Sensor integration can be done using the 0-10V input and 12V auxiliary output
- Secondary switching is not permitted
- Incorrect wiring can damage the LED module

Installation steps

Method of installation varies based on the luminaire manufacturer

- Turn the power off at the circuit breaker before wiring
- Install the driver into the fixture using the screws

Head: CSK Slotted



Length	Head Diameter	Screw Diameter
38mm	8.3mm	3.7mm

- Power the driver connecting the Line and Neutral wires from the mains supply
- Connect Warm, Cool channel from the LEDs to the driver

Do's	Don'ts
Installation should be performed by a qualified electrician	Don't use outdoors
Installation shall be in accordance with all applicable local and NEC codes	Avoid input voltage exceeding maximum rating
Turn the power OFF at circuit breakers before wiring	Don't disassemble the products
Observe the correct polarity of output terminal	
Place devices as far away as possible from metallic materials	
Devices work best in when there is a clear LOS between them	
When placing devices inside metallic boxes, please ensure the antenna comes out of the boxes	

Specifications	Value	Remarks
Input voltage	120-277VAC	-
Input current	0.35A	-
Power consumption	0.5W	-
Typical efficiency	85%	120VAC/50Hz/full load
Power factor	0.95	120VAC/50Hz/full load
Output current	450-800mA	800/700/550/450 Adjusted by dip switch
Output voltage	42VDC	-
Ambient temperature	-20 to 45°C(-4 to 113°F)	@Life-time 50,000h
Turn on delay	<500ms	
THD	<15%	120VAC/50Hz/full load
Lifetime	50,000h	@50°C
Tx power	8dBm	Conductive
Dimensions	324 x 30 x 21mm(12.8 x 1.2 x 0.8in)	L x W x H

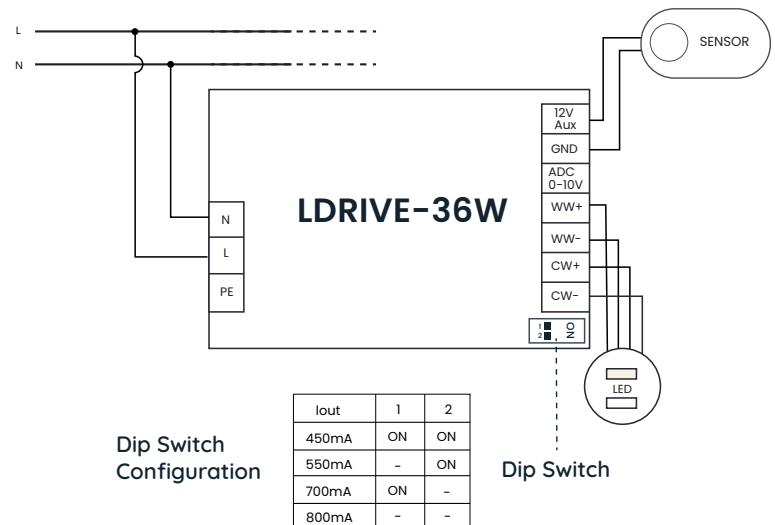

Wiring type and cross section

- The wiring can be in stranded wires with ferrules or solid with a cross section of 15-18AWG (Input) and 20-22AWG(Output).
- Strip 8.5-9.5 mm of insulation from the cables to ensure perfect operation of the push-wire terminals.
- Use one wire for each terminal connector.

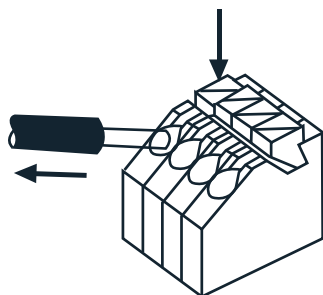

Release of the wires

Press down the "push button" and remove the cable from front

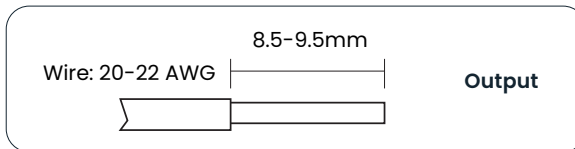
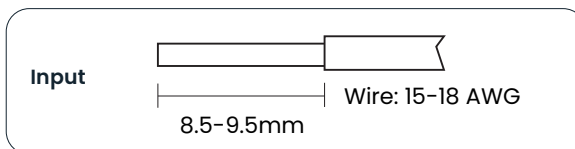

PROTECTION

Short circuit behavior

In case of a short circuit on the secondary side (LED) the LED Driver switches off. After elimination of the short-circuit fault, the LED Driver will recover automatically.

The LED Driver works in burst working mode to provide a constant output voltage regulation which allows the application to be able to work safely when LED string opens due to a failure.

Overload protection

If the output voltage range is exceeded the LED Driver will protect itself and the output current will decrease till LED flicker. After elimination of the overload, the nominal operation is restored automatically.

RF GUIDELINES

If pairing of devices are getting failed continuously then it may be due to BLE traffic. To reduce the traffic, power OFF other devices in the vicinity and pair again.

TROUBLESHOOTING

When returning from a Power Outage, lights go back to ON state.	The device will return to its previous state after the power is restored, as configured using the Lumos Controls mobile app.
Device doesn't operate immediately after power ON	Check whether you have set up a transition time
Lights flickering	<ul style="list-style-type: none"> • The connection is not appropriate • The wires are not secured firmly with connectors
Lights did not turn ON	<ul style="list-style-type: none"> • Circuit breaker tripped • Fuse has blown • Inappropriate wiring

WARRANTY

5-year limited warranty

Please find warranty [terms and conditions](#)

Note: Specifications may change without notice

Actual performance can vary due to end-user environment and application

The cabling, wiring and mounting of LED driver depends on the design and manufacturer of the LED module. Therefore, the instruction provided here should not be viewed as a comprehensive instruction for installation.

For detailed information

- Read the documentation provided by the lamp manufacturer and follow the guidelines provided
- Observe all relevant standards and follow the instructions given

COMMISSIONING

Once powered up, the device will be ready to be commissioned via the Lumos Controls mobile app available for free download on [iOS](#) and [Android](#). To begin commissioning, click the '+' icon from the top of the 'Devices' tab. The app allows you to preset certain configurations which will be loaded after the device is added. The pre-configurations made using 'Commissioning Settings' will be sent to the devices being commissioned. Once commissioned, the device will be displayed in the 'Devices' tab and you can perform individual operations like ON/OFF/dimming on it from this tab.



Please visit [Help center](#) for more details

LUMOS CONTROLS APPLICATION

Download the 'Lumos Controls' application from Play Store or App Store
OR

Scan the QR codes to download the 'Lumos Controls' application



The Bluetooth® word mark and logos are registered trademarks owned by Bluetooth SIG, Inc. and any use of such marks by WiSilica Inc. is under license. Other trademarks and trade names are those of their respective owners.